



SERVICE PARTS LIST

**BULLETIN NO.
54-28-0415**

SPECIFY CATALOG NO. AND SERIAL NO. WHEN ORDERING PARTS		REVISED BULLETIN	DATE
VACUUM PAD ASSEMBLY			Feb. 2009
CATALOG NO. 49-22-7100	STARTING SERIAL NO.	WIRING INSTRUCTION	

EXAMPLE:

00	0
----	---

 Component Parts (Small #) Are Included
 When Ordering The Assembly (Large #).

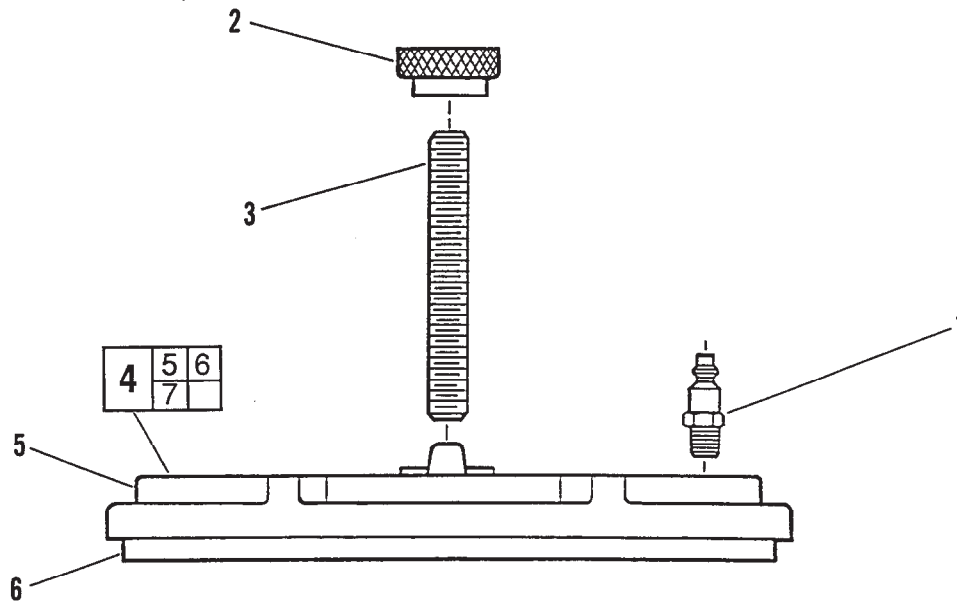

FIG.	PART NO.	DESCRIPTION OF PART	NO. REQ.
1	42-90-0115	Male Coupling	(1)
2	44-40-0200	Hold Down Nut	(1)
3	06-92-1600	6" Vacuum Pad Stud	(1)
4	14-65-0210	Vacuum Pad Assembly (Includes Fig. Nos. 5, 6 & 7)	(1)
5	-----	Vacuum Pad	(1)
6	43-44-0570	Vacuum Pad Gasket	(1)
7	44-22-0060	Rubber Cement (Not Shown)	Tube