



SERVICE PARTS

BULLETIN NO.
54-34-0251

SPECIFY CATALOG NO. AND SERIAL NO. WHEN ORDERING PARTS		REVISED BULLETIN 54-34-0250	DATE June 2012
VACUUM PUMP ASSEMBLY			
CATALOG NO. 49-50-0200	SERIAL NUMBER 908B	WIRING INSTRUCTION SEE BELOW	

EXAMPLE:
Component Parts (Small #)
Are Included When Ordering
The Assembly (Large #).

FIG.	PART NO.	DESCRIPTION OF PART	NO. REQ.
★ 1	23-66-0032	Switch On/Off	(1)
2	22-33-0025	Capacitor	(1)
3	06-82-2295	8-32 x 3/8" Screw T-20	(2)
★ 4	-----	Capacitor Cover	(1)
★ 5	06-82-2290	8-16 x 3/8" Plastite Screw T-20	(2)
★ 6	-----	Capacitor Bracket	(1)
★ 7	44-68-0040	Strain Relief Plug	(1)
8	43-33-0020	Hose Fitting	(1)
9	42-96-0010	Filter Jar	(1)
10	45-80-0010	Check Valve	(1)
11	43-44-0025	Jar Gasket	(1)
12	43-46-0010	Vacuum Gauge	(1)
13	43-31-0020	Filter Core	(1)
14	43-31-0030	Filter Felt	(4)
16	42-92-0080	Manifold Cover	(1)
★ 17	-----	Cylinder Sleeve	(1)
18	45-36-0050	Spacer	(1)
★ 19	-----	Piston Cup	(1)
★ 20	-----	Cup Retainer	(1)
★ 21	-----	10-24 x 5/8" Torx Screw	(1)
★ 22	44-94-0025	Connecting Rod Assembly	(1)
★ 23	42-52-0045	Motor End Cap	(1)
★ 24	06-82-5585	10-24 x 1-1/4" Screw T-25	(2)
★ 25	06-82-5590	10-24 x 1-7/8" Screw T-25	(2)
★ 26	43-62-0025	Handle	(1)
★ 27	34-40-0150	Head Gasket	(1)
★ 28	43-64-0135	Head	(1)
29	-----	Valve Restriant	(1)
★ 30	14-46-0055	Valve Plate Assembly	(1)
★ 31	-----	Valve Keeper Strip	(1)
32	-----	Valve Flapper	(2)
33	-----	6-32 x 3/16" Slotted Head Screw	(2)
34	-----	Valve Plate	(1)
★ 35	34-40-0155	O-Ring	(1)
★ 36	22-84-0030	Fan	(1)
★ 38	43-52-0075	Front Cover Grille	(1)
39	42-36-0015	Bracket	(1)
40	22-90-0020	Vibration Mount Grommet	(4)
41	06-81-1080	10-24 x 5/8" Hex Head Machine Screw	(4)
42	06-97-0060	Lockwasher	(4)
43	06-55-0100	Hex Nut	(4)
44	06-97-0055	Lockwasher	(4)
45	14-37-0122	Hose Assembly	(1)
46	43-75-0020	Hose	(1)
47	43-33-0020	Hose Fitting	(1)
48	42-90-0050	Female Coupling	(1)
50	-----	Cord Set	(1)
51	10-20-6900	Warning Label-Filter Jar (Not Shown)	(1)
52	10-20-6905	Warning Label-Head (Not Shown)	(1)
53	10-20-6910	Arrow Decal (Not Shown)	(1)
54	10-20-6920	Warning Label-Capacitor Cover (Not Shown)	(1)
55	12-70-0145	Stator Label (Not Shown)	(1)
56	-----	Pump Service Tool (Not Shown)	(1)
★ 57	42-36-0040	Capacitor Cover and Bracket Assembly	(1)

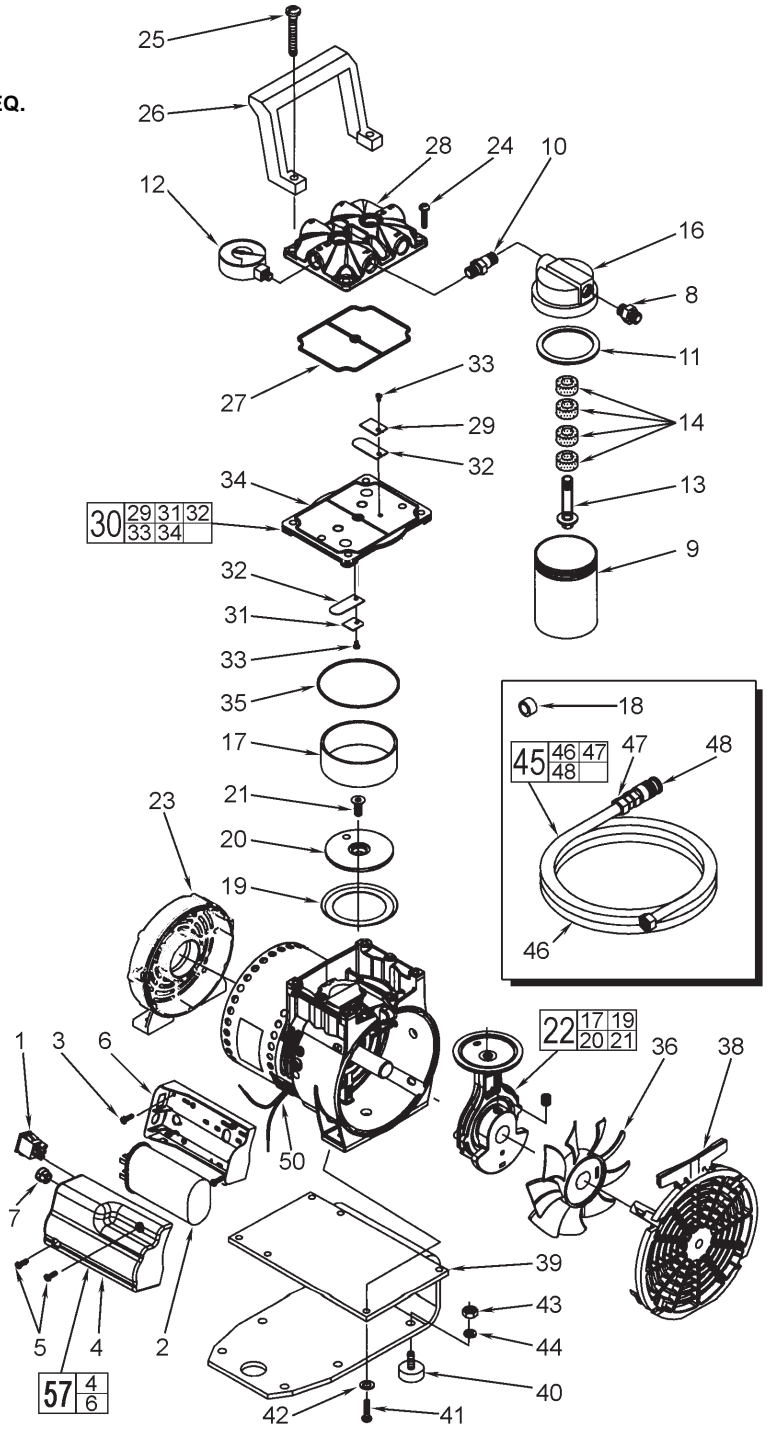

Note: Instructions below are based on the user facing the pump, with the cord on the left side and the capacitor on the right side.

1. Clamp ring on fan, #36 (22-84-0030), must face in towards motor.
2. Circular grooves on valve plate assembly, #30 (14-46-0055), will face down toward connecting rod assembly, #22 (44-94-0025), Valve on top side should be closer to cord side than capacitor side.
3. The letter "E" on the head, #28 (43-64-0135), should be on the cord side of the pump for proper orientation.

